

# User's Manual

---

# FF310

## FaultFinder

for electrical and electronic circuits

---

## Table of contents.

1	Check out list	Page 1
2	Start-up	Page 1
3	Turning on and off the FF310T and FF310R	Page 1
4	Setting the sensitivity level	Page 2
5	How to use the sensor	Page 3
6	Locating short circuits	Page 3
7	Wire tracing	Page 4
8	Locating current leaks	Page 4
9	Locating open circuits	Page 5
10	Wire identification	Page 5
11	Hook up reference chart	Page 6
12	General procedures	Page 7
13	Special tracing procedures	Page 8
14	Technical specifications	Page 10
15	CT8002AA Professional Circuit Tester	Page 10
16	CT6100 Fuse Socket Connectors	Page 11
17	Care of the unit	Page 11
18	Warranty	Page 12

### Caution

#### Very Important: Read this first

- For use only with DC voltage. Do not connect to circuits exceeding 42 volts DC under any circumstances.
- DO NOT USE on AC voltage.
- Do not use on any circuit directly or indirectly connected to AC lines or any other AC power source.
- Do not use with any component or part of the ignition system.
- Before using this device check the vehicle's electrical wiring and disconnect any part or subsystem sensitive to voltage and current pulses such as air bags, electronic control modules, etc.
- Always follow the instructions and procedures indicated in the vehicle's service manual before attempting to disconnect any part or subsystem of the electrical circuit.

**Exceeding the limits listed above when using this apparatus, or not observing the precautions listed above can expose you to physical injury and permanently damage your instrument and parts and components of the vehicle under test.**

# 1 - Check out list

The FF310 FaultFinder set consists of:

- FF310R - Receiver
- FF310T - Transmitter
- CT8002AA Professional Circuit Tester
- CT6100 Fuse Socket Connectors
- 2 factory supplied 9 volt alkaline batteries, type Duracell MN1604
- Foam padded polypropylene carrying case.
- User's manual.

# 2 - Start Up

Both the FF310T and FF310R are factory supplied with batteries. To install the batteries follow the steps below:

1. Open battery drawer at back of each unit (factory supplied batteries are disconnected).
2. Remove the battery, and connect it observing the polarity of the battery connector, repeating the operation on both units.
3. Press the On/Off button on the FF310T, green LED will start flashing. If green LED does not start flashing, check the battery polarity and reinstall if necessary. To turn the unit off, press the On/Off button again.
4. Press the On/Off button on the FF310R, green LED will turn on. If the green LED does not turn on, check the battery polarity and reinstall if necessary. To turn the unit off press the On/Off button again.

# 3 - Turning On and Off the FF310T and FF310R

## FF310T

The transmitter is turned on and off by momentarily pressing the On/Off button, and it must be turned off manually after use by pressing the On/Off button. Before storing the unit check to make sure that all lights are off, failure to do so will result in a much shorter battery life.

## FF310R

The receiver can be turned on and off manually by momentarily pressing the On/Off button, however after 3 minutes of not being used, it will turn off automatically to conserve battery power. Turning the unit off manually will prolong battery life.

## Low battery indicator

From time to time the batteries on both units will need to be replaced. When the battery is below the minimum operating voltage, upon turning the unit on (FF310T and FF310R) both lights will flash for 1 second and the unit will turn off automatically. In this case replace the batteries with a new set of 9 Volt alkaline batteries. To install the new batteries, follow the instructions in the preceding section: **2 – Start Up**.

## 4 - Setting the sensitivity level

The FF310R has three user selectable sensitivity ranges: '**Low**', '**Medium**' and '**High**'. These ranges allow the technician to choose the degree of sensitivity most suitable to the particular detection being performed.

### 4.1 Checking the current sensitivity setting:

The FF310R's current sensitivity setting is displayed when the On/Off button is pressed for 2 or 3 seconds while the unit is 'ON' (steady green indicator on). The high sensitivity setting generates a quick triple flashing of the green LED, a double flashing in the medium sensitivity range and a single flashing indicates a low sensitivity level setting.

Green LED shows a:

FF310R set to:

Single (1) flash and beep	—————>	<b>Low</b> sensitivity
Double (2) flash and beep	—————>	<b>Medium</b> sensitivity
Triple (3) flash and beep	—————>	<b>High</b> sensitivity

When turned off, the FF310R will retain the last selected sensitivity setting.

### 4.2 Procedure to select the FF310R's range :

1. Unit should be on, if not, turn it on by momentarily pressing the On/Off button.
2. Press and hold On/Off button for approximately 3 seconds until a beeping and flashing occurs. This initial beeping and flashing indicates the current sensitivity level setting. By holding the On/Off button pressed, the FF310R will cycle to the next sensitivity setting following the pattern indicated below:

- I- **Low** Sensitivity: single (1) flash and beep.
- II- **Medium** Sensitivity : double (2) flash and beep.
- III- **High** Sensitivity : Triple (3) flash and beep.

The sensitivity level is selected in the following sequence:

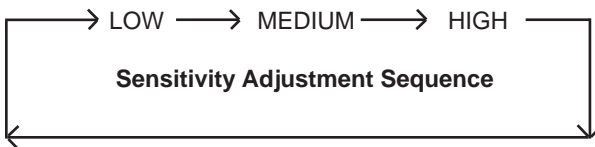

For example: If the FF310R unit is set to '**MEDIUM**', in order to set the sensitivity to **LOW**, press the On/Off button until a double beep and flashing occurs (current setting), keep holding the button pressed and a triple beeping and flashing occurs (setting now is **HIGH**), keep holding the button pressed, until a single flash and beep indicates that the new setting is **LOW**.

## 5 - How to use the sensor:

The probe of the FF310R is built of coiled steel equipped with a sensor (yellow cylinder), and can be bent as needed, in order to reach wires in congested or difficult areas. Depending on the circuit characteristics and the sensitivity setting, the probe's sensor will pick-up the signal from the wire in a wide range of positions. However for the best possible range, the FF310R's sensor (yellow cylinder) should be positioned perpendicular (at 90°) to the wire being traced and either above or below it, as shown in Fig. 1 below.

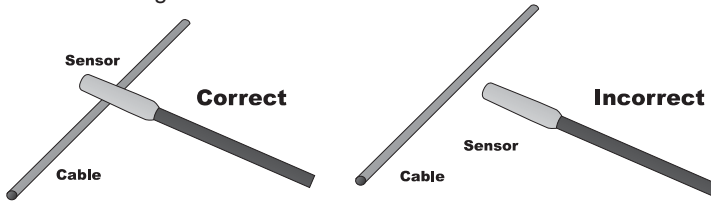

Fig. 1 - Sensor positioning

## 6 - Locating Short Circuits

Refer to the Hook Up Reference Chart in Page 6.

- 6.1 Observe the limits and safety precautions at all times (refer to the beginning of this handbook).
- 6.2 Connect the FF310T in series with the short-circuited wire, making sure one of the unit's clips is connected to the circuit's positive supply (or vice versa for vehicles with positive supply connected to chassis). A fuse socket connector (in place of the blown fuse), a connector, etc., provides a convenient hook up as shown in Fig. 2 and Fig. 3 in Page 6.
- 6.3 Switch the FF310T on by pressing the On/Off button and observe if the red LED on the FF310T starts flashing. If not check the connections, power supply, and in the case of having connected the unit to any place other than the fuse socket, check that the circuit's fuse is installed and in working condition (not open). If necessary replace with a new fuse with the same ratings.
- 6.4 Switch the FF310R on, insuring the green LED turns on.
- 6.5 Verify that the FF310R is set to the lowest sensitivity level (single green LED flash).
- 6.6 Slowly sweep the wire, conduit, etc., ensuring the FF310R's sensor is perpendicular and above or below the wire being traced and as close as possible to it.
- 6.7 Follow the wire or check it at different points, starting from the FF310T and moving towards the load (accessory, light, etc.) observing the positioning of the sensor as indicated above. Continue this procedure while the audio signal (beeping sound) and visual signal (flashing red LED light) indicates the integrity of the circuit. If beeping and flashing slows down or stops it indicates that the sensor is either moving away from the faulty wire or it has passed beyond the short circuit point.
- 6.8 If difficult or impossible to get the FF310R to pick-up any signal, then increase the sensitivity level, and start again from step 6.6.
- 6.9 Double check positioning the sensor before and after the suspected place. If the short circuit point has been located, the audio/visual indicators will show circuit integrity on for one position, but not for the other.

6.10 The short circuit is located in the area where the audio/visual signal stops or changes significantly.

6.11 When the test is completed, switch off the FF310T unit pressing the On/Off button and disconnect from circuit.

**Note:** The closer the FF310R's sensor is to the wire carrying the signal, the faster the beeping and the flashing will be. Some times it will prove advantageous to reduce the sensitivity level to pinpoint more accurately the faulty area.

## 7 - Wire tracing

Wire tracing hook up and procedures are essentially the same as for locating short circuits. The FF310T sees the load (light bulb, accessory, etc.) as a weak short circuit or connection to ground. For wire tracing simply follow the wire with positive (beeping and flashing) audio/visual indicator's feedback on the FF310R from source to load.

For step by step directions please refer to point **6 – Locating Short Circuits**, for some hints and specific differences refer to the notes below:

The type and size of load connected to the circuit (impedance or resistance to ground) determines the amount of current allowed to flow in the circuit. Small loads (low Wattage lamps, electronic systems, etc.) will reduce the range of the FF310R accordingly. In cases where the full range of the FF310R is required to follow the wire, it may prove advantageous to use one of the two methods described below:

- **Tracing wires downstream** (from supply to load): replacing the load for a full short circuit allows the FF310R to work at its maximum capabilities. Before proceeding, remove all electrical power from the circuit, connect the FF310T in series with the wire to trace, short circuit the load to ground (refer to **Hook Up Reference Chart** Fig.2 and 3), then reconnect power and follow instructions in section **6 – Locating Short Circuits**.
- **Tracing wires upstream** (from load to supply): If more convenient, wires can also be traced the other way around, by replacing the load with the FF310T (Fig. 5 of Hook Up reference chart). To do this, first remove power from the circuit, disconnect the load and connect the FF310T in its place. Apply power to the circuit and follow instructions in section **6 – Locating Short Circuits**.

## 8 – Locating Current Leaks

Hook up and procedures for locating current leaks are essentially the same as for locating short circuits. The FF310T sees the leak as a weak short circuit or connection to ground. For locating a current leak simply follow the wire with positive (beeping and flashing) audio/visual indicator's feedback on the FF310R, from source to leak location (short circuit).

For step by step directions please refer to point **6 – Locating Short Circuits**, for some hints and specific differences refer to the notes below:

### **Current leak notes:**

- The type and size of the leak in the circuit (impedance or resistance to ground) determines the amount of current flowing in the circuit. Small leaks (i.e. low current) will reduce the range of the FF310R accordingly. In all cases the FF310R's sensor should be positioned as close as possible to the wires, in order to maximize the signal captured by the FF310R, and set to a higher sensitivity level . For hook up refer to the **Hook Up Reference Chart** Fig. 2 and 3 in Page 6.

## 9 - Locating Open Circuits

Refer to the Hook Up Reference Chart in Page 6.

- 9.1 Observe the limits and safety precautions at all times (refer to the beginning of this handbook)
- 9.2 Connect the FF310T in series with the open ended wire, making sure one of the unit's clips is connected to the circuit's positive supply or ground . A fuse socket (with the fuse removed), a connector, etc., provides a convenient hook up as shown in Fig. 2, 3, 4 and 5 of the **Hook Up Reference Chart**.
- 9.3 Make sure that the clips are firmly attached to their connection points, and switch the FF310T on by pressing the On/Off button. Observe if the green LED on the FF310T starts flashing. In the case of having connected the unit to any place other than the fuse socket, check that the circuit's fuse is installed and in working condition (not open). If necessary replace with a new fuse with same rating.
- 9.4 Switch the FF310R on, insuring the green LED turns on and set if necessary the sensitivity level to "**LOW**".
- 9.5 Slowly sweep the wire with the FF310R, ensuring the sensor is perpendicular to and above or below the wire being traced and as close as possible to it .
- 9.6 Follow the wire or check it at different points, starting from the FF310T and moving towards the load (accessory, light, etc.), observing the positioning of the sensor as indicated above. Continue this procedure while the audio signal (beeping sound) and visual signal (flashing green LED light) indicates the integrity of the circuit. If beeping and flashing slows or stops, it indicates that the sensor is either moving away from the wire or it has passed beyond the open, break or bad connection in the circuit.
- 9.7 If difficult or impossible to get the FF310R to pick-up any signal, then increase the sensitivity level and start again from step 9.5.
- 9.8 Double check by positioning the sensor before and after the suspected place. If the open circuit point has been located, the audio/visual indicators will show circuit integrity on one side, and not on the other.
- 9.9 At this point, where the audio/visual signal stops, you have found the open circuit.
- 9.10 When the test is completed, switch off the FF310T unit pressing the On/Off button and disconnect from circuit. You may also switch off the FF310R by pressing the On/Off button on the unit. However to conserve power, the FF310R will automatically turn off after 3 minutes of not being used.

**Note:** The closer the FF310R's sensor is to the wire carrying the signal, the faster the beeping and the flashing will be.

## 10 - Wire identification

Refer to the **Hook Up Reference Chart** in Page 6.

Wiring can be identified by following the hook up and procedures for locating short circuits or open circuits, depending on the particular configuration of the circuit.

- **For identifying wires with load connected:** Connect the FF310T as described in section '**6- Locating Short Circuits**' to the circuit to be identified, then proceed to scan all suspected wiring with the FF310R's sensor until the flashing and beeping is at its maximum. In the case of tightly packed wires ( bundles, conduits, etc.), it may be necessary to spread these apart to facilitate the identification process of a particular wire.

- **For identifying wires without load connected:** Connect the FF310T as described in section '9- Locating Open Circuits' to the circuit to be identified, then proceed to scan all suspected wiring with the FF310R's sensor, until the flashing and beeping is at its maximum. In the case of tightly packed wires ( bundles, conduits, etc.), it may be necessary to spread these apart to facilitate the identification process of a particular wire.

## 11- Hook up reference chart

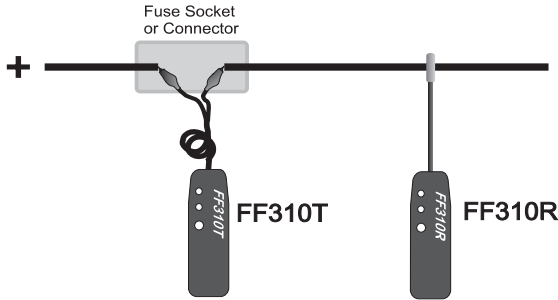

Fig.2 - Set up for tracing short or open circuits, or location of wiring

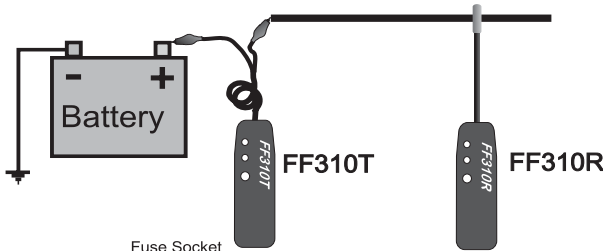

Fig.3 - Set up for tracing short and open circuits, or tracing wiring

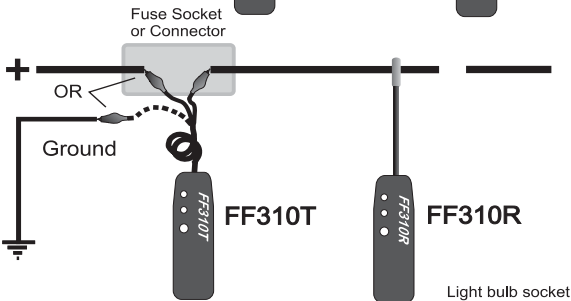

Fig.4 - Set up for tracing open circuits or identification of wires

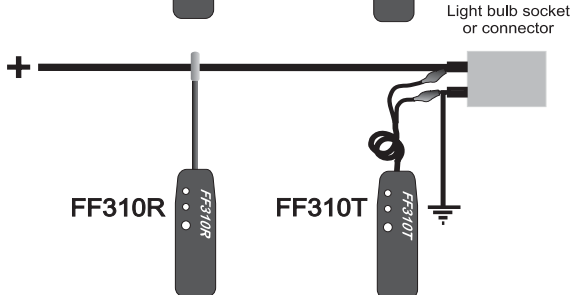

Fig.5 - Set up for upstream tracing of open circuits or location of wires



## 12 - General Procedures

### Short and open circuit operation – Differences:

The FF310 FaultFinder set uses two different types of signals to trace either short or open circuits. Understanding its differences, as explained in the following paragraphs will allow you to make the most effective use of this versatile tool.

#### 12.1 Working with open circuits

On detection of an open circuit, the FF310T injects a special radio signal into the circuit, which can be picked up by the FF310R's sensor.

When tracing an open circuit, keep in mind that RF (radio frequency) signals injected in the faulty wire being traced, will be easily absorbed by any other conductor nearby. (e.g.: other wires, metal frames). The effect of this absorption may vary from a reduction in the FF310R's range, to a total shielding of the signal with no detection being possible at all (See Fig. 6).

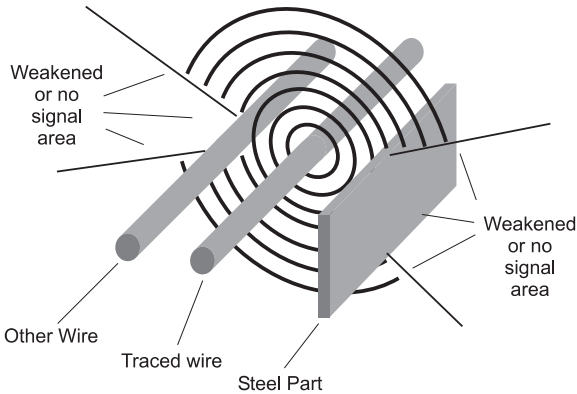

Fig. 6 - Detection field when tracing open circuit with the FF310R

In order to avoid confusing a shielded portion of the faulty wire with the actual fault on it, the circuit should be checked on in several places to confirm that no signal is detected on the other side of the suspected faulty section.

#### 12.2 Working with short circuits (and tracing circuits)

When the FF310T detects a short circuit (or closed circuit), it injects pulses of electrical current in the wires, which generate magnetic fields. Unlike radio signals, magnetic fields are not easily absorbed by nearby conductors and therefore can be picked up by the FF310R's sensor in a wider range of situations (See Fig. 7).

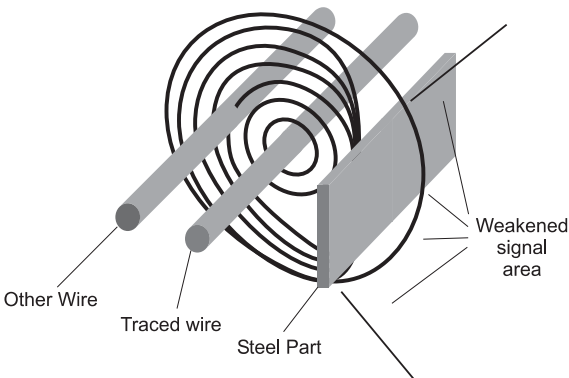

Fig. 7 - Detection field when tracing short-circuits with the FF310R

### 12.3 Some circuit characteristics that may affect the tracing of a wire:

- Electromagnetic loop size and geometry, etc. may affect the range of the FF310R. For example for circuits in which the live and ground (return) wire run parallel and close to each other in the same circuit, the two magnetic fields interaction may weaken the signal, thereby reducing the FF310R range.
- Wires enclosed or tightly lining the metal frame or body of the vehicle, (i.e.: door frames), have the same effects as having the live and ground wires running in parallel in the same circuit since, the metal frame or vehicle body will be acting as a ground wire. Another unfavorable factor may be due to the channeling effect steel parts have on magnetic fields. These two cases, individually or combined, will reduce and sometimes impede the tracing of the wire sections affected.

**Hint:** Whenever possible the short circuit mode of operation should be used, because it provides with the best tracing capabilities.

## 13 - Special Tracing procedures

- In all cases, first set the FF310R at the lower sensitivity level and increase it as necessary. Proceed as indicated in the sections of this User's Manual applicable to your situation.
- Always after locating a probable fault area, verify several points in the wires on both sides (before and after) the suspected area. The signal should be present at only one side of the fault (open or short). This procedure will help avoid confusing a signal loss with the actual trouble point.

### 13.1 Wire bundles and conduits:

- Special care should be given in the case of tracing a wire inside a bundle or conduit when there is a split. In this case it may be possible to follow the wrong branch for a short distance and still receive a positive audio/visual indication.
- To avoid following the wrong path, which could happen if the FF310R's sensor picks up the signal from the other nearby branch of the circuit, the branches should be swept maintaining the sensor outside the apex area between the split, as shown in Fig. 8.
- Careful attention should be paid to the beeping and flashing speed of the FF310R unit indicators, as these provide the necessary feedback to evaluate the proximity of the sensor to the wire being traced.

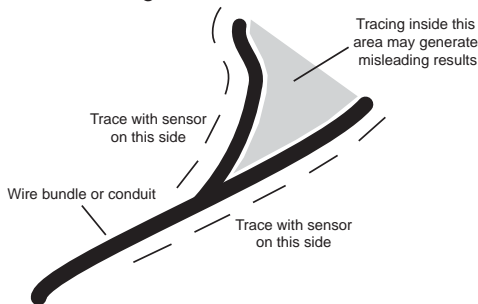

Fig. 8 - Tracing Wires inside bundles and conduits

### 13.2 How to increase the pick up range when tracing wires

- When tracing or identifying wires connected to lightly loaded circuit (low currents), this reduces the range of pick up significantly. A possible solution is after connecting the FF310T in series with the circuit to trace, is to replace the load (light bulb, module, etc.) with a direct connection to ground. This allows the FF310T to inject a more powerful signal which is easier to detect.
- For the cases in which it is suspected the layout of the wires is the cause of a very difficult to pick up or weak signal, a dramatic increase of the range can be accomplished by "spreading" the circuit.

- The spreading the circuit is achieved by connecting a jumper wire between the live wire (preferably at a termination point in the circuit such as a light bulb socket, switch, etc.), and a ground point somewhere else in the vehicle ( see Fig. 9). This last method should be used only as “last resource” and with the FF310R set to low sensitivity, as it could make the pinpointing of the precise location more difficult due to the much increased range.
- Always verify that the FF310T is connected in series with the circuit being tested and that its red indicator light is on, as this confirms a proper connection and will limit the amount of current flowing in the circuit.

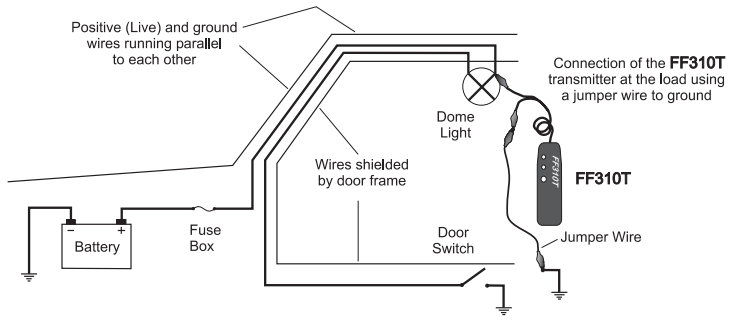

Fig. 9 - Simplified dome light circuit hook up for wire tracing

### 13.3 Circuits with multiple loads or branches

- When tracing circuits connected to, or which are powering multiple loads and/or branches (See Fig. 10), and when these circuits are active or live, the bulk of the current injected into the circuit by the FF310T will be directed to the shorted branch of the circuit. However smaller amounts of current (or stray currents) will flow to the other branches as long as these provide a path to ground (i.e. close the circuit).
- These stray currents present in the non-shortened branches of the circuit, and depending on the circuit configuration and physical layout of the wires, could be picked up by the FF310R, making the tracing procedures confusing, and even misleading.
- The simplest and most effective way to deal with these cases, is to disconnect or remove all the loads from the circuit being traced (i.e. removing light bulbs in example shown in Fig. 10).

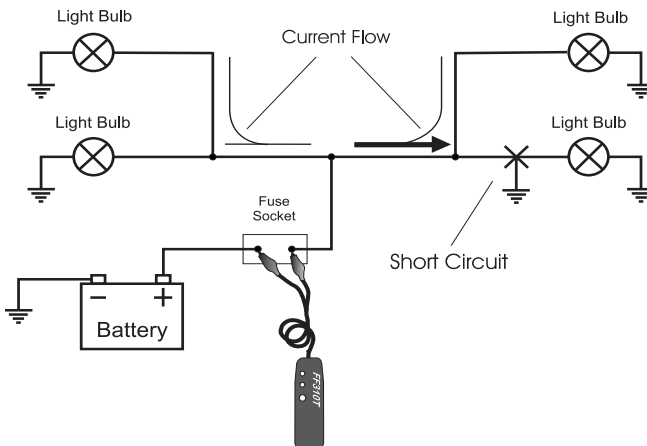

Fig. 10 - Schematic of a single circuit with multiples loads

## 14 - Technical specifications

### *FF310T - Transmitter*

**Voltage range:** 6 to 42 volts DC.

**Indicator:** Flashing green LED indicator for power on or open circuits.  
Flashing red LED indicator for short circuits.

**Power source:** 9 volt alkaline battery, Duracell MN1604 or equivalent.

**Connector:** Two 5 Amp. universal micro-clips with auto polarity and 18" long cable.

**Battery life:** Approximately 25 hours of use.

### *FF310R - Receiver*

**Sensitivity:** 3 User selectable levels (Low, Medium and High)

**Probe:** Flexible 8" gooseneck insulated steel probe with sensor.

**Indicator:** Green LED indicator for Power On and Open Circuits. Red LED indicator for short circuits. Audio signal for shorts and opens. Variable flashing and modulated audible signal.

**Power source:** 9 volt alkaline battery. Duracell MN1604 or equivalent.

**Battery life:** Approximately 25 hours of use.

## 15 - CT8002AA Professional Circuit Tester

### Instructions

- 1-Hold tester by metal barrel and place free hand on bare (grounded) metal part of the vehicle.
- 2-Place tester point into connector or wire (pierce insulation if necessary).
- 3-Tester will emit a sound, vibrate, and the red light turn on when a positive voltage is detected.

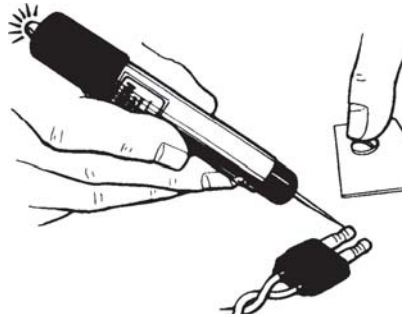

### V-Groove Protector Tip uses:

- 1- Always insert the V-Groove protector tip on the tester point before carrying or storing the unit, as this may avoid injuries.
- 2-Use the V-Grove protector tip when piercing wires to prevent the tester point from side-slipping on the wire and causing injuries or damage.
- 3-The protector tip may be removed for testing in hard to reach places inside connectors, sockets, etc.

### Replacing the battery:

The battery supplied with the tester will provide years of service under normal use. When the sound, vibration, and light starts to fade, remove the screw and pull out the plastic pointer assembly. Remove the battery and insert a new type IEC LR6 - ANSI/NEDA 15A (AA size alkaline) or equivalent battery, observing the polarity (negative side goes in first). Insert the tester point assembly, then align the holes and replace the screw.

## 16 - CT6100 Fuse Socket Connectors

The CT6100 fuse socket connectors are designed to facilitate the connection of the test leads of the FF310T to the circuit under test through the fuse box, and can also be used for all other situations when access to the fuse socket connections are required. These connectors are supplied in three sizes: Mini, ATO and Maxi.

### How to use the CT6100 connectors

- 1-Choose the connector (Mini, ATO or Maxi) that matches the fuse socket where the connection is required.
- 2-Remove the power to the circuit.
- 3-Insert fuse connector into the socket (see figure).
- 4-Connect test leads to the connectors tabs of the fuse socket connector.

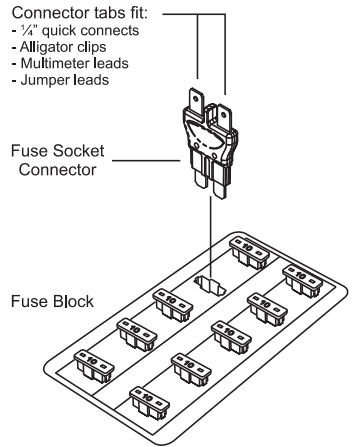

## 17 - Care of the Unit

The FF310 is a precision instrument and should be treated as such. Damage caused by mistreatment is not covered by the warranty.

Keep the units in their carrying case when not in use and do not subject to dampness or severe heat or cold. Do not use the units in the rain, if they should accidentally get wet, dry them off with a clean paper towel before storing away.

Protect the units from contact with any solvents. Never clean with a solvent or petroleum based medium such as gasoline, as these chemicals may attack the plastic parts and cause permanent damage. Never use an abrasive cleaner. Cleaning should be limited to wiping with a clean damp paper towel with a small amount of soap if required. Dry the units thoroughly after any cleaning.

These are sealed instrument and contains no user serviceable parts other than the battery which can be replaced by opening the drawer on the back of the units. Opening other parts of the units will void the warranty.

## 18 - Warranty

With the exception of the batteries, your FF310 is warranted against defects of material or workmanship which develop within a period of one (1) year following the date of purchase by the original owner. Proof of date of purchase will be required when applying for repair or replacement under guarantee. For this reason, we strongly suggest that you keep your sales receipt safely in your FF310 storage case.

In the event a flaw develops in the FF310, please return it to your dealer who will arrange repair or replacement. The manufacturer will either repair or replace the tool (at the manufacturer's option) free of charge providing the FF310 is still under warranty. If the warranty has expired, there will be a repair charge payable to your dealer when you pick up the unit. When a unit has been repaired or replaced under warranty, the replacement unit will continue the warranty period of the original unit for six (6) months after the date of replacement or until the original warranty expires, whichever is the longest period. This warranty shall not apply to any defect, failure or damage caused by improper use or inadequate maintenance or care.

The manufacturer shall not be obligated to provide service under this warranty or to repair damage resulting from attempts by unauthorized persons to repair or service the FF310, other than to replace the battery; or to repair damage resulting from improper use. Specifically if there is evidence of an attempt to open the FF310 the warranty is void.

Any implied warranties arising out of the sale of the FF310 including but not limited to implied warranties of merchantability and fitness for a particular purpose are limited in duration to the above one (1) year period, the manufacturer shall not be liable for loss of use of the FF310 or other incidental damages, expenses or economic loss. Some Jurisdictions do not allow limitations on how long implied warranties last or the exclusion or limitation of incidental or consequential damages, so the above may not apply to you.

Part # FF310MN1707EN

---

To visit our website, scan the QR code below with your smart phone.



© 1996-2017 General Technologies Corp.  
Printed in Canada

---

"V Ready" and "GTC" are trademarks of General Technologies Corp.